

IA FLEX CUBE WORKSTATION

Assembly Instructions

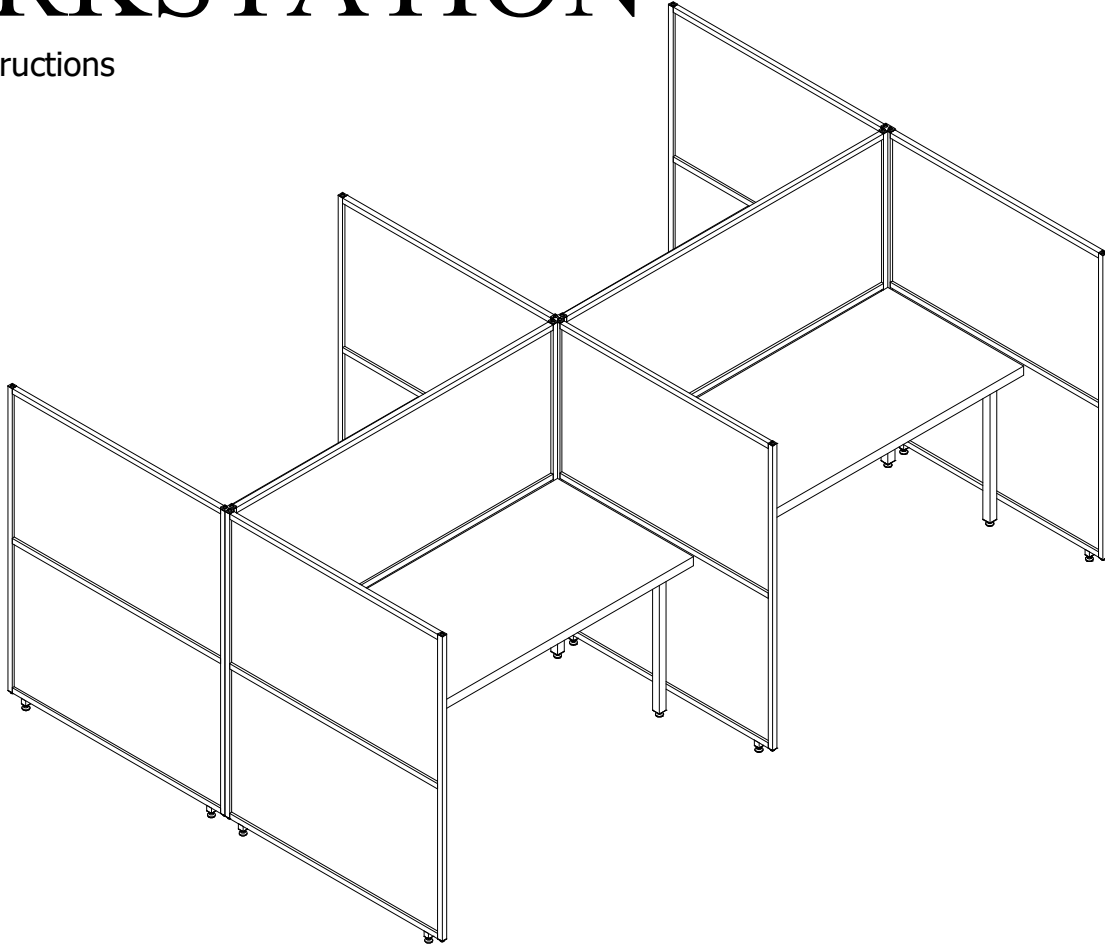

Thank you for your purchase!

Iron Age Office furniture is uniquely and individually fabricated. For this reason, your furniture is pre-assembled and labeled before shipping. Labels are marked on the underside of the furniture. Most furniture is then deconstructed prior to shipping. Pieces that uniquely correspond can typically be found on the same pallet.

Assembly is best completed by keeping the pieces that correspond together. Clear your work area of anything that could scratch furniture surfaces. If possible, cover your work area with a clean, soft blanket. Carefully flip any wooden tops over and inspect the bottom sides for markings.

Match legs, flat brackets, etc.
to the appropriate labels.

If you need further assistance of any kind,
please contact:

Iron Age Office Operations Manager

Henry Dover

678-725-1473 (c)

hd@ironageoffice.com

HARDWARE

Screws are shown actual size. You may receive extra hardware with your unit.

Tools Required



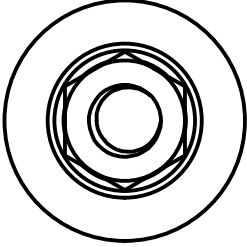
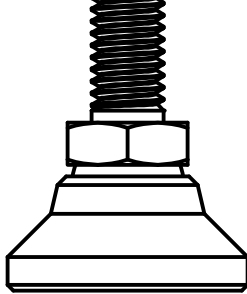

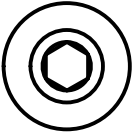
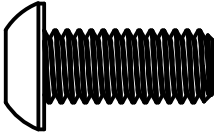

① 14-10 LAG BOLT   #3 Square Drive

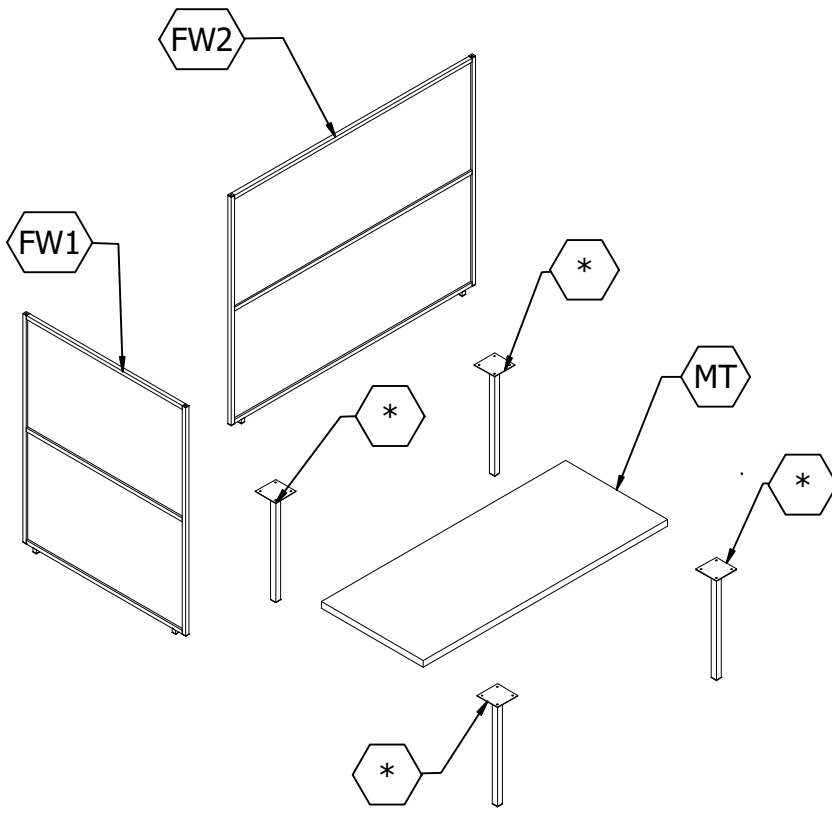
④ LEVELING FOOT   9/16 Crescent Wrench

⑦ 3/8-16 BOLT   7/32 Hex Drive

PARTS



-  STANDARD LEG
-  SHORT WALL
-  LONG WALL
-  MAIN TOP
-  END CAP
-  T BRACKET
-  CROSS BRACKET

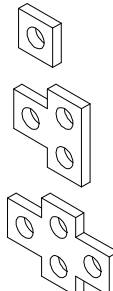

ASSEMBLY

STEP 1

Screw in leveling feet to bottoms of all walls.

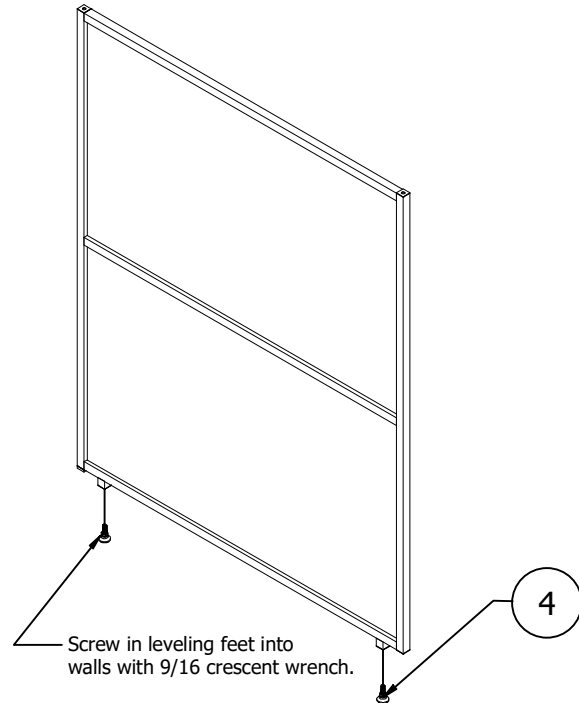

STEP 2

Flip one short wall to an upright position. Secure two end caps to the top and bottom of the wall using 3/8-16 bolts.

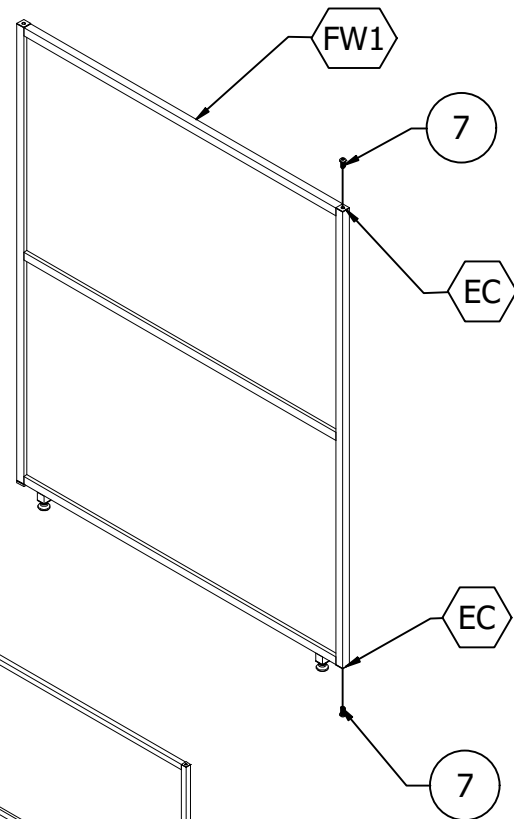
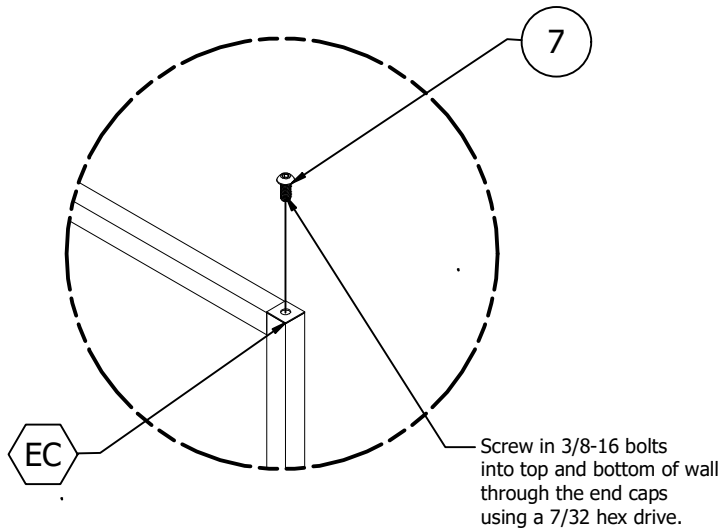

STEP 3

Flip another short wall to an upright position. Repeat step 1 and secure end caps to end of the wall. Align walls together. Secure walls together with (2) T- brackets on top and bottom connections using 3/8-16 bolts.

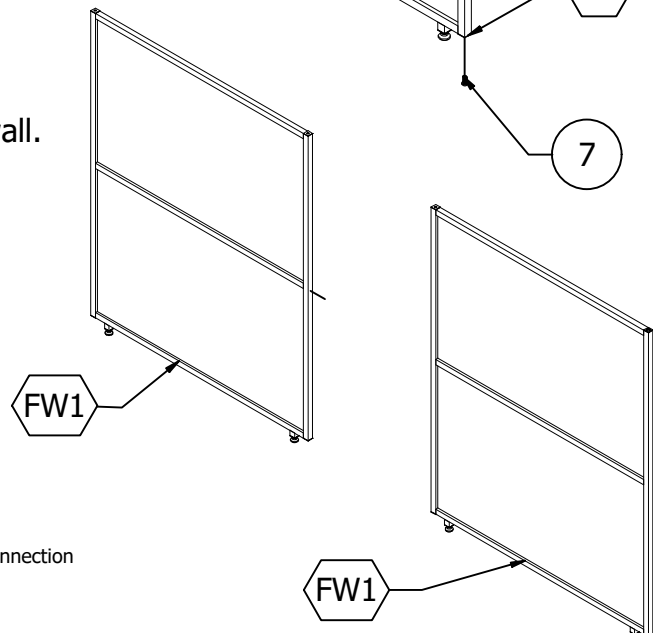
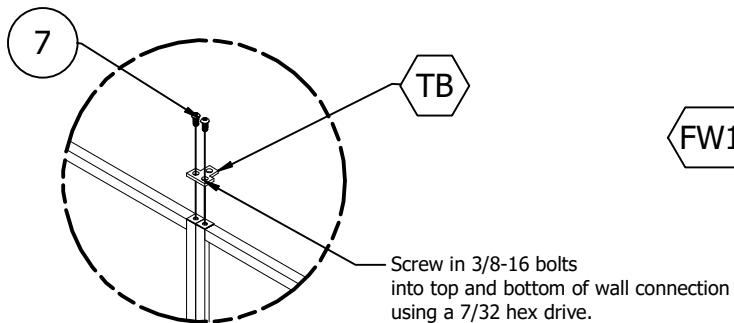

ASSEMBLY

STEP 4

Align long wall to the connection of the short walls. Secure long wall with 3/8-16 bolts into T-brackets at top and bottom of the walls.

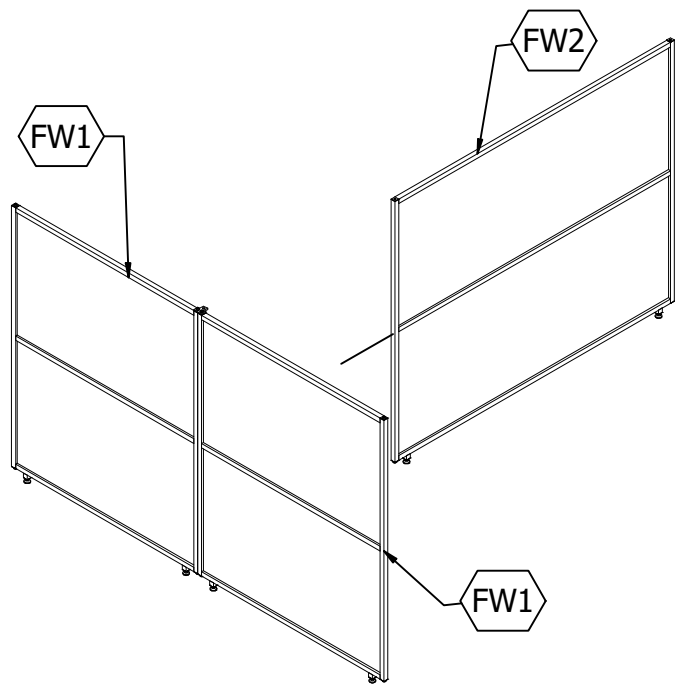
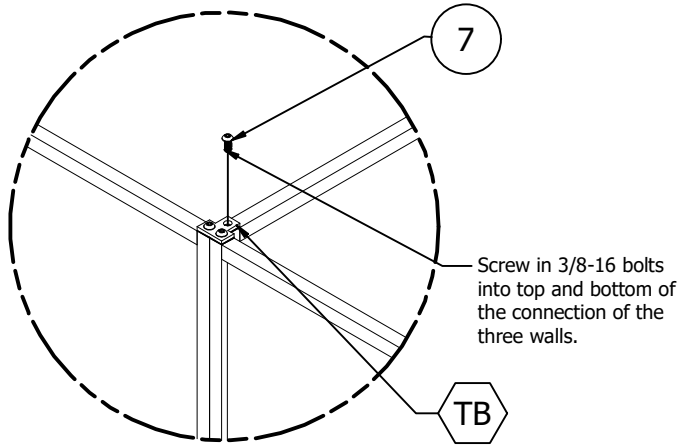

STEP 5

Align short wall to the long wall. Secure short wall to long wall with 3/8-16 bolts into cross brackets on top and bottom of walls.

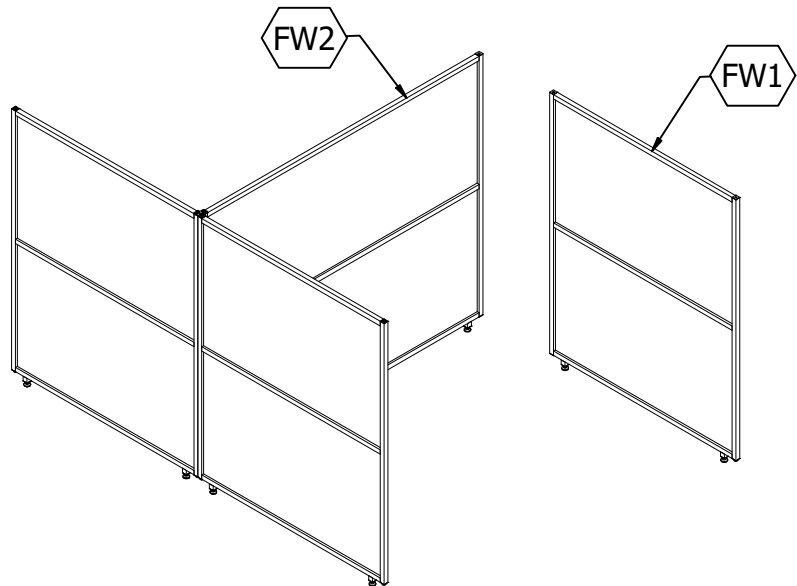
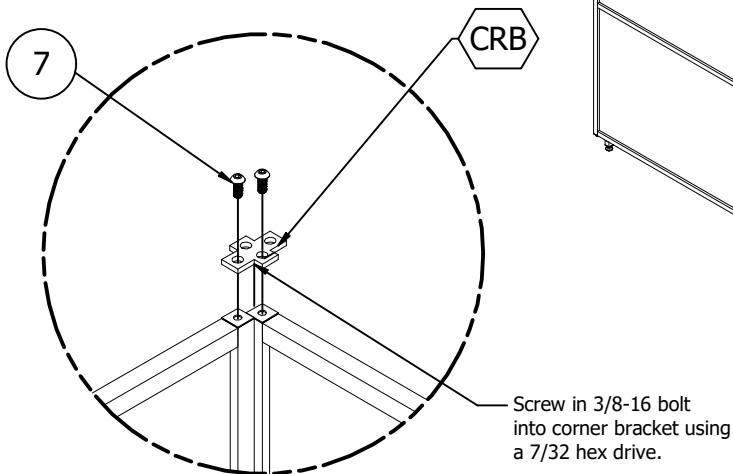

STEP 6

Align another short wall to connection of the long and short wall in previous step. Repeat step 1 and secure end caps to end of the wall. Secure walls together at cross bracket with 3/8-16 bolts at top and bottom of walls.

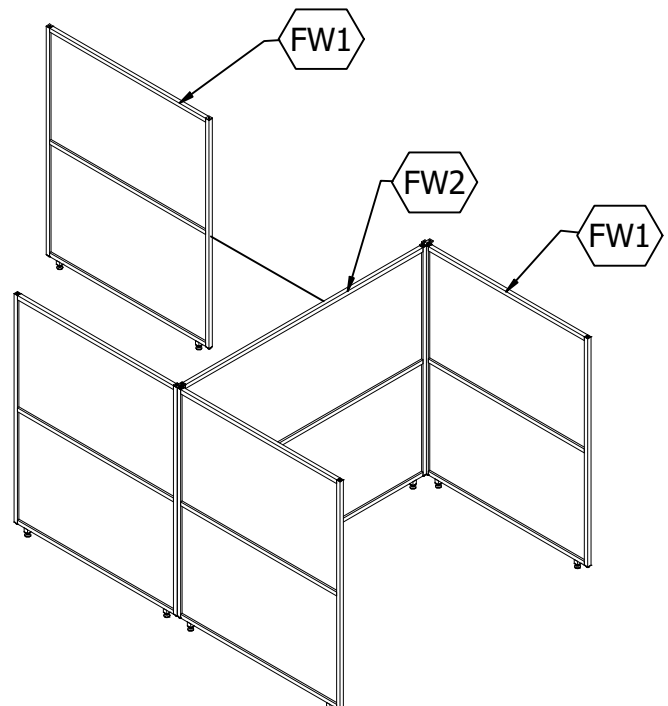
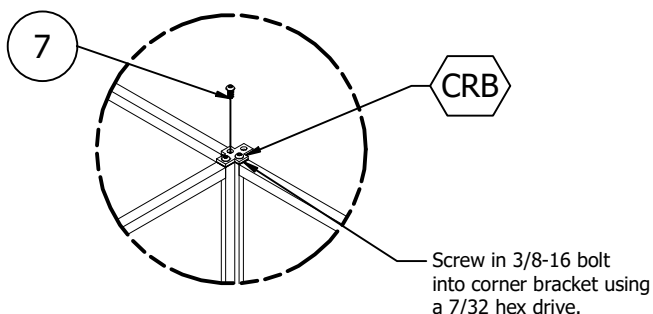

ASSEMBLY

STEP 7

Align and secure long wall to connection of the long and short walls to the cross bracket with 3/8-16 bolts.

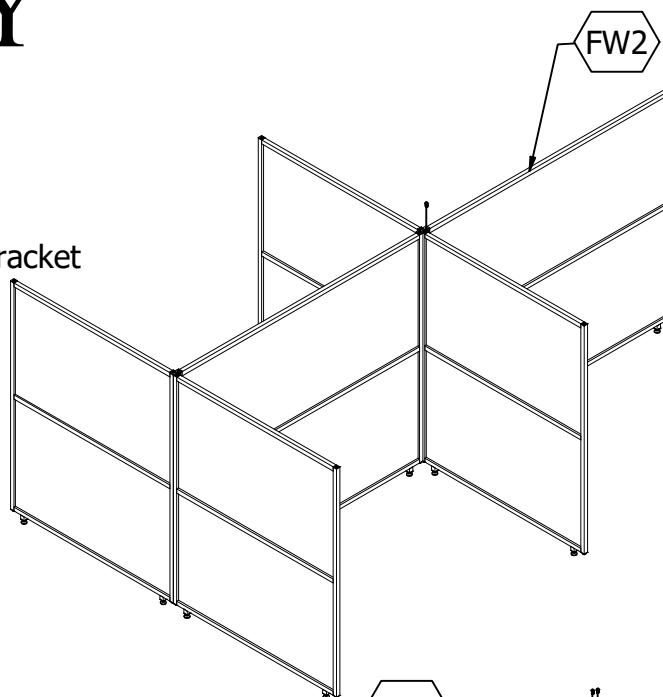

STEP 8

Align and secure short wall to long wall with T-brackets at top and bottom of walls. Repeat step 1 and secure end cap to the end of the wall.

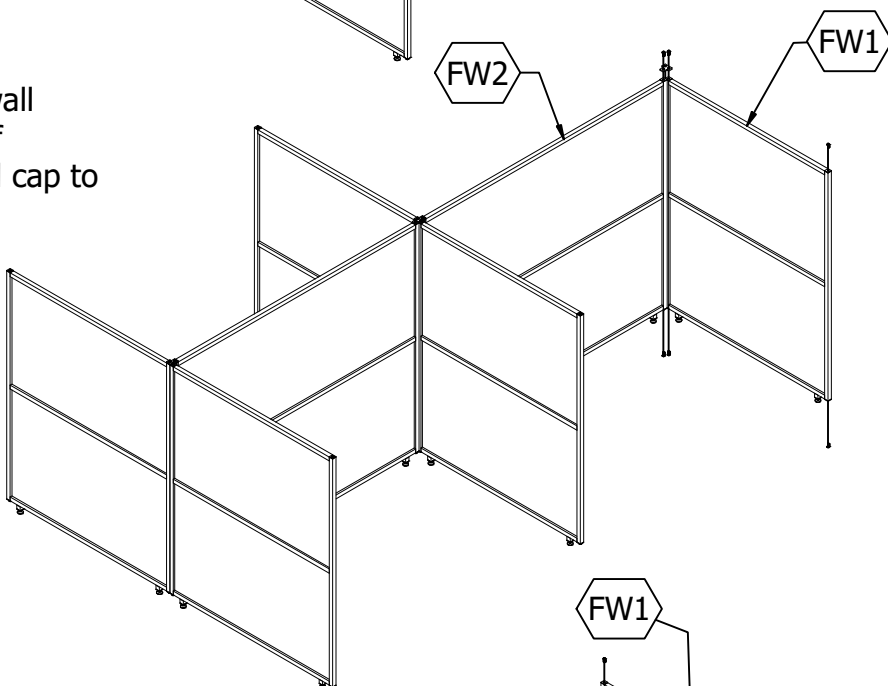

STEP 9

Align and secure another short wall to connection from previous step. Repeat step 1 and secure end cap to the end of the wall.

**For additional workstations repeat steps 4-8.*

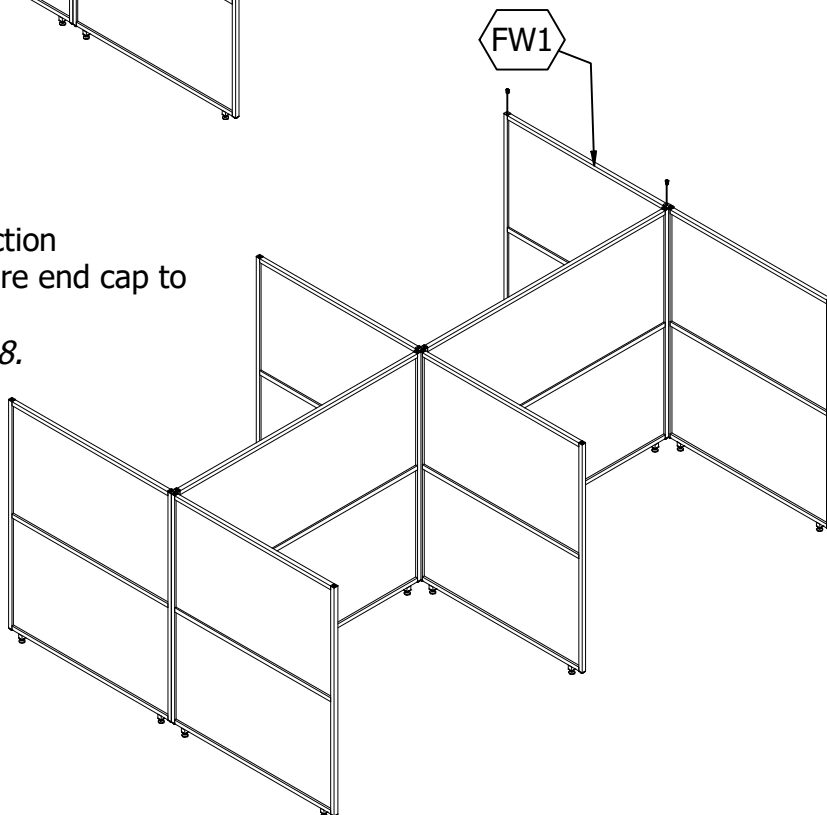

ASSEMBLY

STEP 10

Begin building your desks.
Place all tops face down on a clean surface.

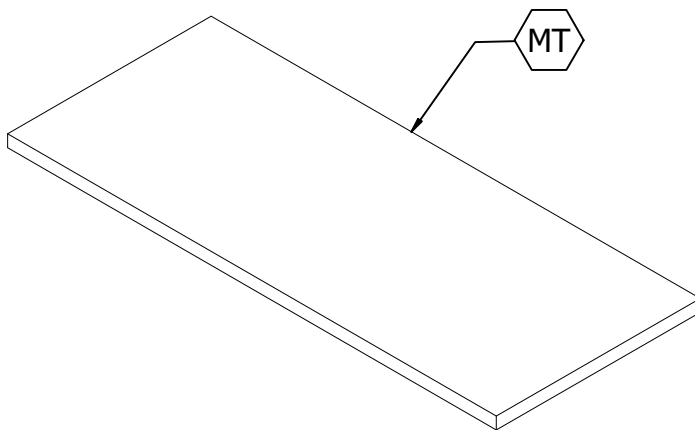

STEP 11

Align legs to tops using markings on desk. Secure with (4) 14-10 lag bolts in each leg.

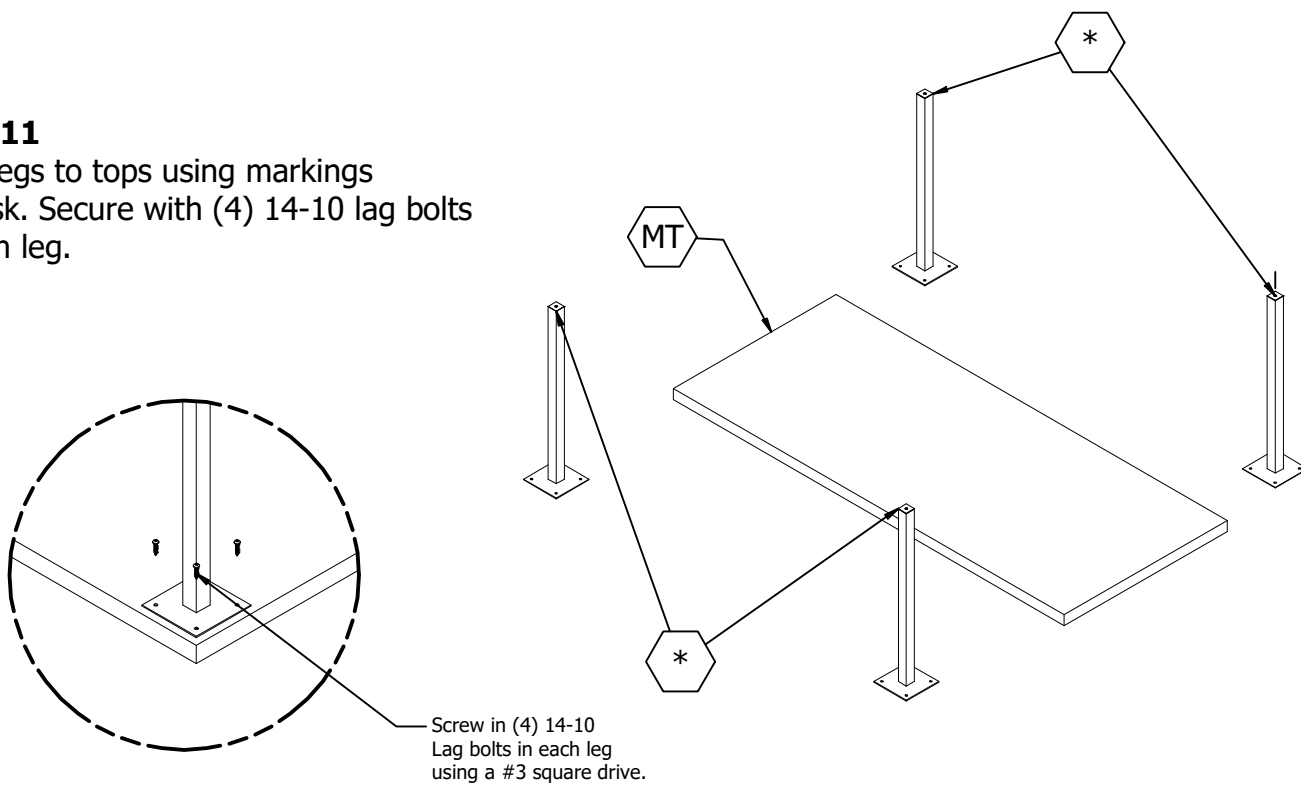

STEP 12

Screw in leveling feet into all legs.

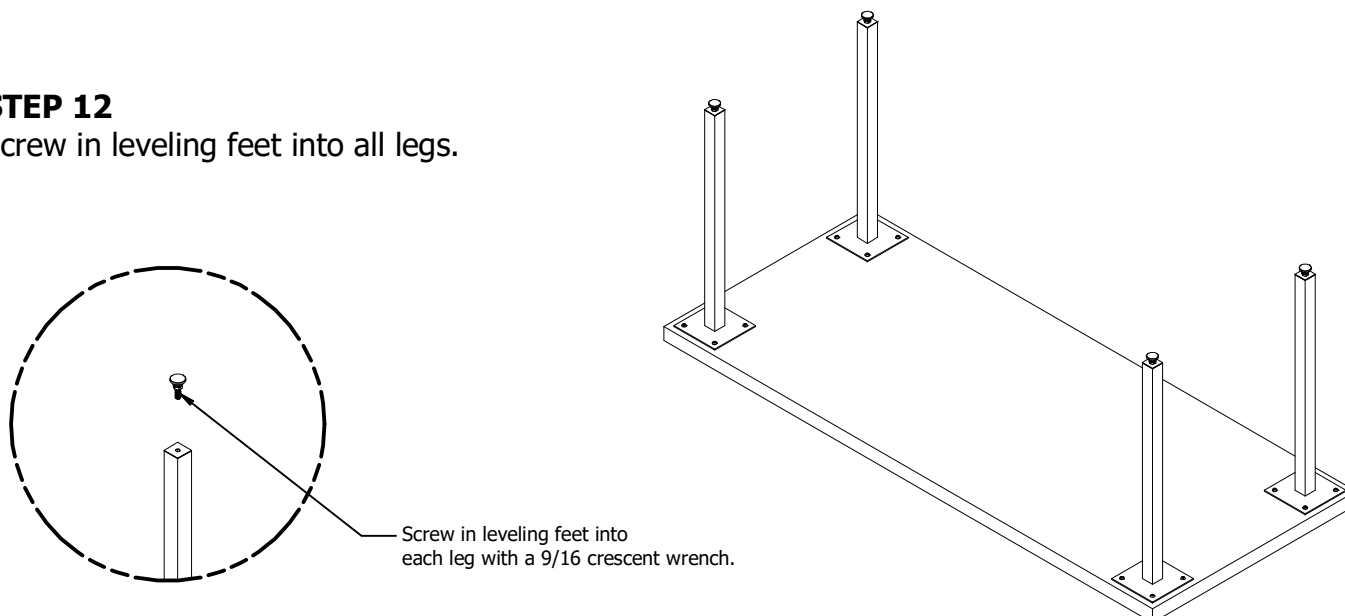

ASSEMBLY

STEP 13

Flip desks to an upright position and align to cubes.

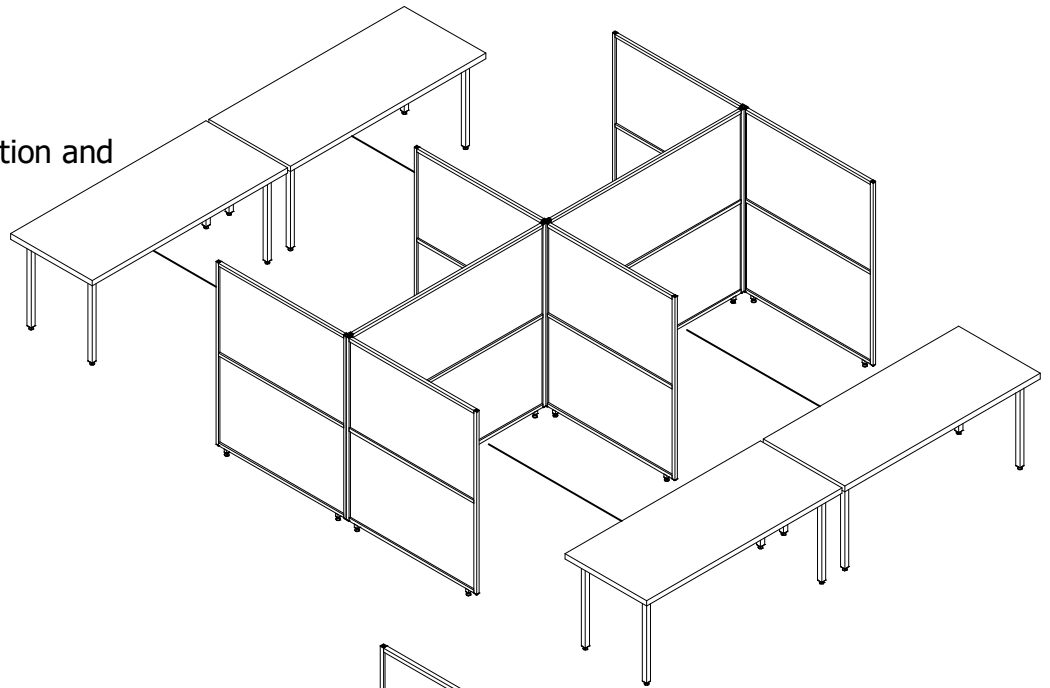

STEP 14

Enjoy your workstation!

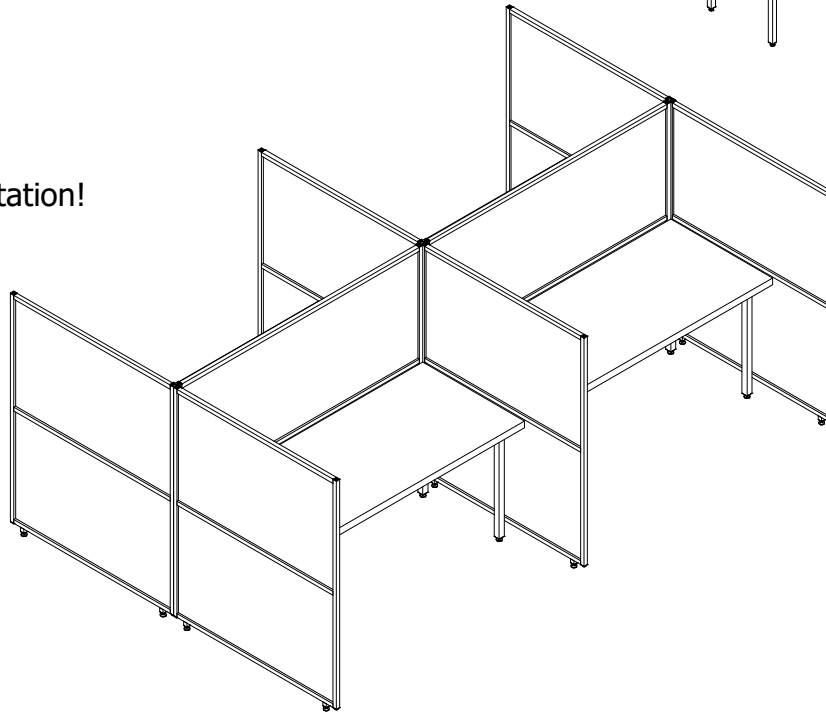

CARE INSTRUCTIONS

To care for either wooden or metal surfaces of Iron Age Office products, gently wipe with a soft cloth dampened with water and a mild dishwashing liquid. Once satisfied, dry with a soft cloth.